



casagrande



**Hydraulic
crawler drill**

Perforatrice idraulica

M9-1

Dati tecnici

Technical Specifications

M9-1





Caratteristiche Carro	Undercarriage			
Larghezza sottocarro	Overall width of undercarriage	8.2 ft	2500 mm	
Larghezza pattini	Track shoe width	19.7 in	500 mm	
Lunghezza cingoli	Overall track length	10.6 ft	3235 mm	
Velocità di traslazione	Travel speed	0 ÷ 1.1 mph	0 ÷ 1,8 km/h	
Pendenza max. superabile	Max. gradeability	37%	20°	
Pressione al suolo	Ground pressure	11 PSI	7,5 N/cm ²	
Oscillazione cingoli	Oscillating tracks	+16°/-14°	+16°/-14°	
Motore	Engine	Deutz		
Tipo	Type	TCD 2012 L06 2V (EPA/COM III)		
Potenza a 2300 rpm	Rated power at 2300 rpm	198.5 HP	147 kW	
Mast	Mast	A	B	
Lunghezza mast	Mast length	20.7 ft / 6300 mm	27,6 ft / 8400 mm	
Corsa testa di rotazione	Stroke of rotary head	14.4 ft / 4400 mm	21.3 ft / 6500 mm	
Forza di estrazione	Extraction force	19.110 lbs / 85 kN	19.110 lbs / 85 kN	
Spinta sull'utensile	Crowd force	11.240 lbs / 50 kN	11.240 lbs / 50 kN	
Morse	Clamps	M2Z/M2SZ	M4/M4S	M5/M5S
Diametro	Diameter	40 ÷ 254 mm 1.6 ÷ 10 in	60 ÷ 305 mm 2.4 ÷ 12 in	90 ÷ 406 mm 3.5 ÷ 16 in
Forza di chiusura	Clamping force	145 kN 32,600 lbs	250 kN 56,200 lbs	250 kN 56,200 lbs
Testa di rotazione	Rotary head	T1200 6V		T2000
Coppia max.	Max. torque	13500 Nm 9,960 ft lb		17900 Nm 13,200 ft lb
Giri max.	Max. speed	530 rpm		223 rpm
Ingombri e pesi	Dimensions and weights	A		B
Lunghezza	Length	28 ft / 8545 mm		32 ft / 9707 mm
Larghezza	Width	8.2 ft / 2500 mm		8.2 ft / 2500 mm
Altezza	Height	9.3 ft / 2850 mm		9.3 ft / 2850 mm
Peso attrezzatura	Weight of rig	39,680 lb / 18000 kg		40,785 lb / 18500 kg

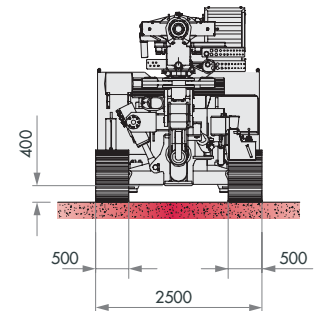
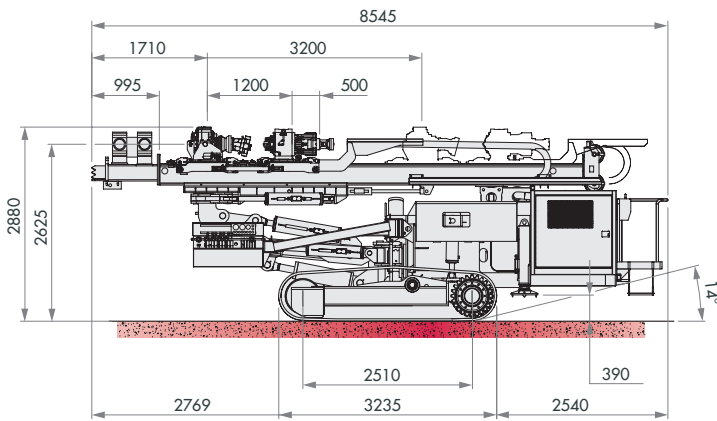
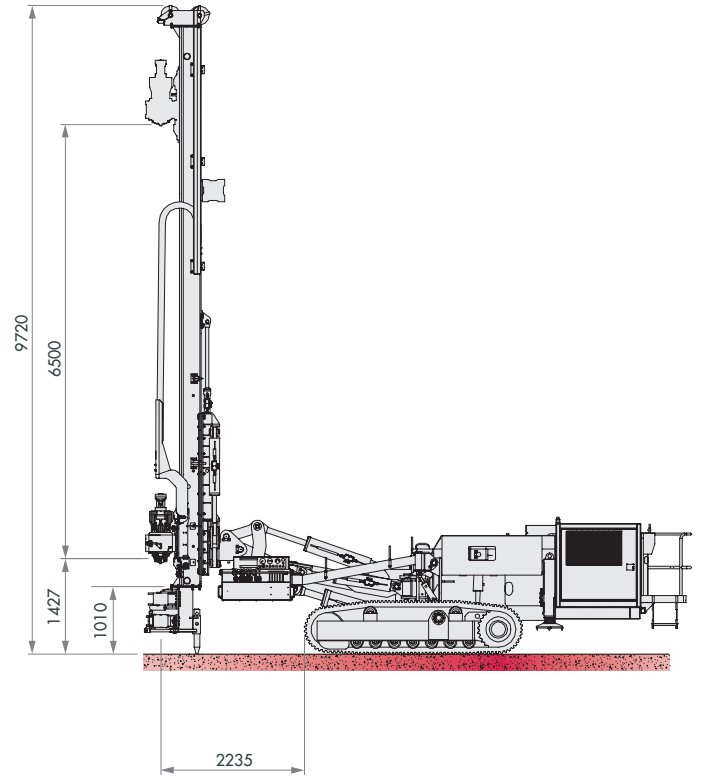
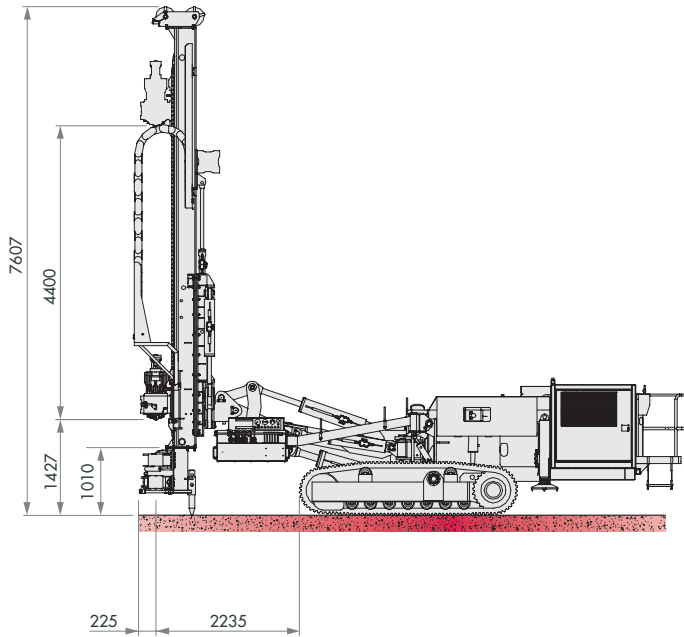

M9-1

Dimensioni Dimensions





M9-1

Movimentazioni mast Mast movements

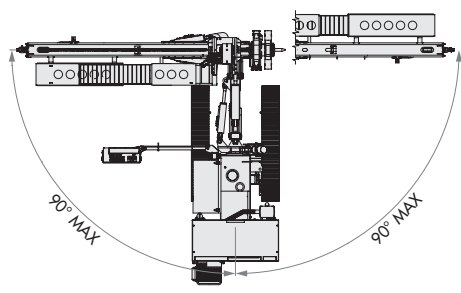
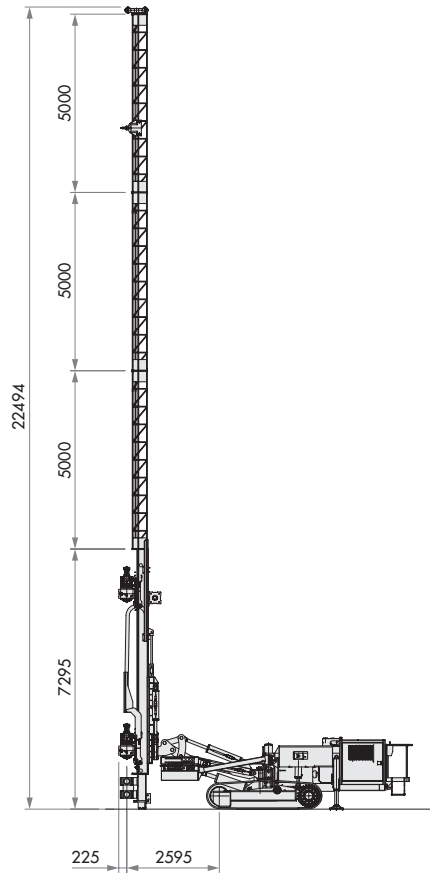
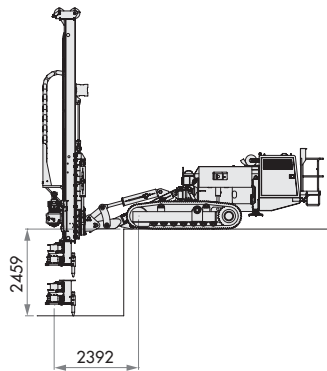
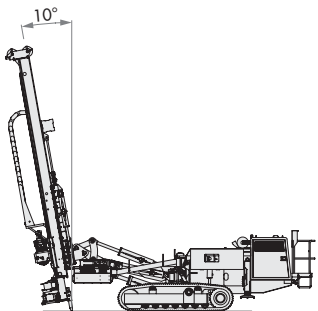
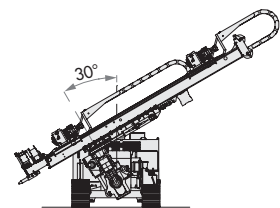
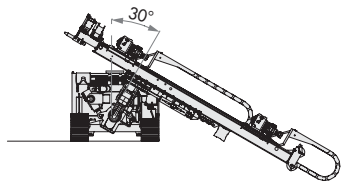
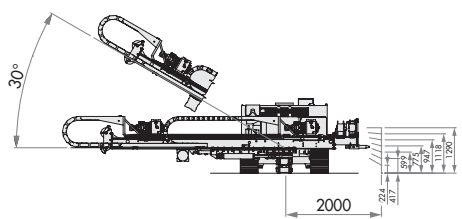
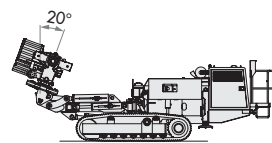
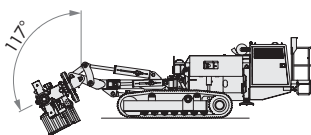
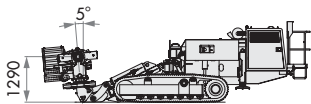
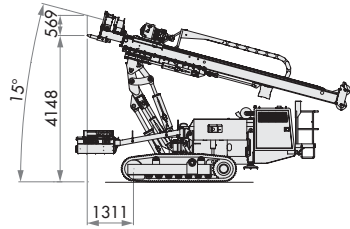
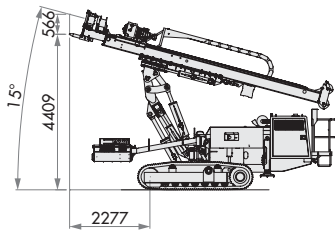
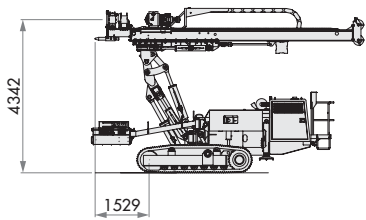

M9-1





OPTIONALS

Stabilizzatori posteriori
 Rotazione idraulica del pulpito
 Testa rotary tipo T1500
 Testa rotary tipo T2500
 Kit applicazione seconda testa
 Applicazione martello D21
 Applicazione martello D21B
 Applicazione mandrino P114
 Applicazione mandrino P200
 Impianto jet temporizzato
 Argano di servizio A2, tiro 20 kN
 Falchetto per argano A2
 Prolunga per falchetto da 2.5 m
 Prolunga tralicciata HD da 15 m per jet grouting
 Oliatore di linea da 24 l
 Pompa schiumogeni tipo C35: 50 bar / 30 l/min
 Pompa scarotatrice: 120 bar / 13 l/min
 Pompa a vite per acqua tipo NG530L: 24 bar / 170 l/min
 Pompa triplex per acqua tipo P246: 40 bar / 200 l/min
 Caricatore 2 aste
 Caricatore 7 aste - uso verticale
 Gru ausiliaria

Rear stabilizers
Hydraulically operated rotation for control panel
Rotary head type T1500
Rotary head type T2500
Application kit for double rotary head
D21 hydraulic drifter
D21B hydraulic drifter with back device
P114 hydraulic chuck
P200 hydraulic chuck
Jet timer
A2 type hydraulic service winch, line pull 20 kN
Jib for A2 winch
2,5 m jib extension
15 m HD lattice mast extension for jet grouting application
24 l oiler
Foam pump type C35: 50 bar / 30 l/min
Volumetric pump: 120 bar / 13 l/min
Screw pump for water flushing type NG530L: 24 bar / 170 l/min
Triplex water pump type P246: 40 bar / 200 l/min
Rod loader for 2 rods
Rod carousel for 7 rods - only vertical
Auxiliary crane